

# KYUDO

design: Hansandfranz / 2010

# KUNDALINI

Lampada da terra con diffusore montato su binario scorrevole regolabile a piacere. Struttura in estruso di alluminio verniciato lucido. Led strip a bassa tensione.

*Floor lamp with diffuser mounted on adjustable sliding track. Glossy varnished extruded aluminium structure. Low voltage Led strip.*



## CERTIFICAZIONI - CERTIFICATIONS



Apparecchio di classe II  
Product in class II

IP20

Apparecchio per uso interno  
Product for indoor use



Apparecchio conforme alla direttiva europea 2006/95/EC  
Product in conformity with the European directive 2006/95/EC



Apparecchio di illuminazione da smaltire secondo la direttiva EU 2002/96/EC  
This lamp must be disposed in conformity with the EU directive 2002/96/EC

## DIMENSIONI - DIMENSIONS

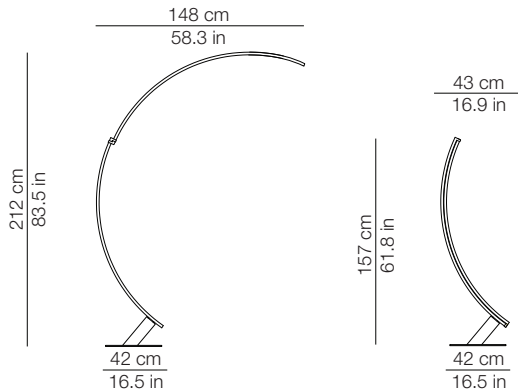

## IMBALLO - PACKAGING

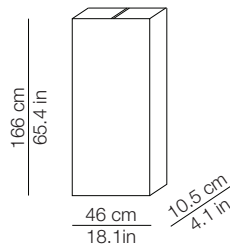

Volume: 0.080 m<sup>3</sup> / 2.831 ft<sup>3</sup>  
Gross weight: 6.9 kg / 15.2 lbs

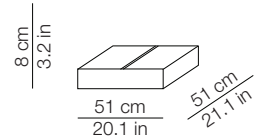

Volume: 0.021 m<sup>3</sup> / 0.735ft<sup>3</sup>  
Gross weight: 7.5 kg / 16.5 lbs

## MATERIALI E FINITURE - MATERIALS AND FINISHINGS

corpo - base  
body - base

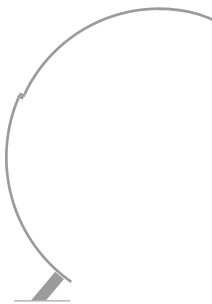

bianco - white  
RAL 9016



rosso - red  
RAL 3020



nero - black  
RAL 9005



cromato - chromed

Struttura in estruso di alluminio verniciato lucido.  
Glossy varnished extruded aluminium structure.

bianco - white



diffusore  
diffuser



PC - Opale, lucido  
PC - opal, glossy

## INFORMAZIONI AGGIUNTIVE - FURTHER INFORMATION

230V  
or  
120V

Alimentazione  
Feeding

Lampadine - Bulbs  
2x21,6W - 2700 K- 4200 lm - CRI>80 - Led strip



Energy efficiency class A+

Lampada da terra  
Floor lamp



Cavo di alimentazione trasparente  
Spina EU, USA o UK  
Transparent cord set  
EU, USA or UK plug



Varialuce rompifilo elettronico 0/100% - trasparente  
Electronic loose dimmer 0/100% - transparent

